

Basic Parameters

Model	-	GWH24BCEXF-K6DNA1A
Product Code	-	CB665002100
Power Supply	Rated Voltage	V~ 220-240
	Rated Frequency	Hz 50
	Phases	- 1
Power Supply Mode	-	Outdoor
Cooling Capacity	W	7100
Heating Capacity	W	7800.00
Cooling Power Input	W	1868
Heating Power Input	W	1902
Cooling Current Input	A	8.7
Heating Current Input	A	9
Rated Input	W	2800
Rated Cooling Current	A	12.3
Rated Heating Current	A	16.00
Air Flow Volume	m ³ /h	1250/1100/1000/950/900/850/800/600
Dehumidifying Volume	L/h	2.50
EER	W/W	3.80
COP	W/W	4.10
SEER	-	8.5
SCOP (Average/Warmer/Colder)	-	4.6/5.7/3.6
Application Area	m ²	23-34

Indoor Unit Parameters

Indoor Unit Model	-	GWH24BCEXF-K6DNA1A/I
Indoor Unit Product Code	-	CB665N02100
Fan Type	-	Cross-flow
Fan Diameter Length (DXL)	mm	Φ111.5X830
Cooling Speed	r/min	1250/1100/1000/950/900/850/800/650
Heating Speed	r/min	1400/1250/1100/1050/1000/900/850
Fan Motor Power Output	W	70
Fan Motor RLA	A	0.65
Fan Motor Capacitor	μF	/
Evaporator Form	-	Aluminum Fin-copper Tube
Evaporator Pipe Diameter	mm	Φ7
Evaporator Row-fin Gap	mm	2-1.4
Evaporator Coil Length (LXDXW)	mm	840X25.4X381
Swing Motor Model	-	MP24HF/MP35CP
Swing Motor Power Output	W	1.5/2.5
Fuse Current	A	5
Sound Pressure Level	dB (A)	Cooling:48/44/41/40/38/37/35/27 Heating:50/47/43/41/40/38/36
Sound Power Level	dB (A)	Cooling:65/59/56/55/53/51/48/42 Heating:64/62/58/56/55/51/50
Dimension (WXHxD)	mm	1144X333X250
Dimension of Carton Box (LXWXH)	mm	1191X407X327
Dimension of Package (LXWXH)	mm	1196X415X337
Net Weight	kg	16.5
Gross Weight	kg	19.5

Outdoor Unit Parameters

Outdoor Unit Model	-	GWH24AVEXF-K6DNA1A/O
Outdoor Unit Product Code	-	CB601W00200
Compressor Manufacturer	-	ZHUHAI LANDA COMPRESSOR CO., LTD.
Compressor Model	-	QXFS-A150zX170S
Compressor Oil	-	FW68DA or equivalent
Compressor Type	-	Rotary
Compressor LRA.	A	35.00
Compressor RLA	A	11.35
Compressor Power Input	W	1330
Compressor Overload Protector	-	/
Throttling Method	-	Electron expansion valve
Set Temperature Range	°C	Cooling:16~30 Heating:8~30
Cooling Operation Ambient Temperature Range	°C	-15~50
Heating Operation Ambient Temperature Range	°C	-15~30
Condenser Form	-	Aluminum Fin-copper Tube
Condenser Pipe Diameter	mm	Φ7
Condenser Rows-fin Gap	mm	2-1.4
Condenser Coil Length (LXDXW)	mm	890X38.1X616
Fan Motor Speed	rpm	800
Fan Motor Power Output	W	60
Fan Motor RLA	A	0.8
Fan Motor Capacitor	μF	/
Outdoor Unit Air Flow Volume	m ³ /h	3200
Fan Type	-	Axial-flow

Fan Diameter	mm	Φ520
Defrosting Method	-	Automatic Defrosting
Climate Type	-	T1
Isolation	-	I
Moisture Protection	-	IPX4
Permissible Excessive Operating Pressure for the Discharge Side	MPa	4.3
Permissible Excessive Operating Pressure for the Suction Side	MPa	2.5
Sound Pressure Level	dB (A)	60
Sound Power Level	dB (A)	70
Dimension (WXHxD)	mm	958X660X402
Dimension of Carton Box (LXWXH)	mm	1029X453X715
Dimension of Package (LXWXH)	mm	1032X456X737
Net Weight	kg	42.5
Gross Weight	kg	47
Refrigerant	-	R32
Refrigerant Charge	kg	1.4

Connection Pipe Parameters

Connection Pipe Length	m	5
Connection Pipe Gas Additional Charge	g/m	40
Outer Diameter Liquid Pipe	inch	1/4"
Outer Diameter Gas Pipe	inch	5/8"
Max Distance Height	m	10
Max Distance Length	m	25

Note: The connection pipe applies metric diameter.

The above data is subject to change without notice. Please refer to the nameplate of the unit.

24K

Heating operation ambient temperature range is -15°C~30°C

Cooling ►

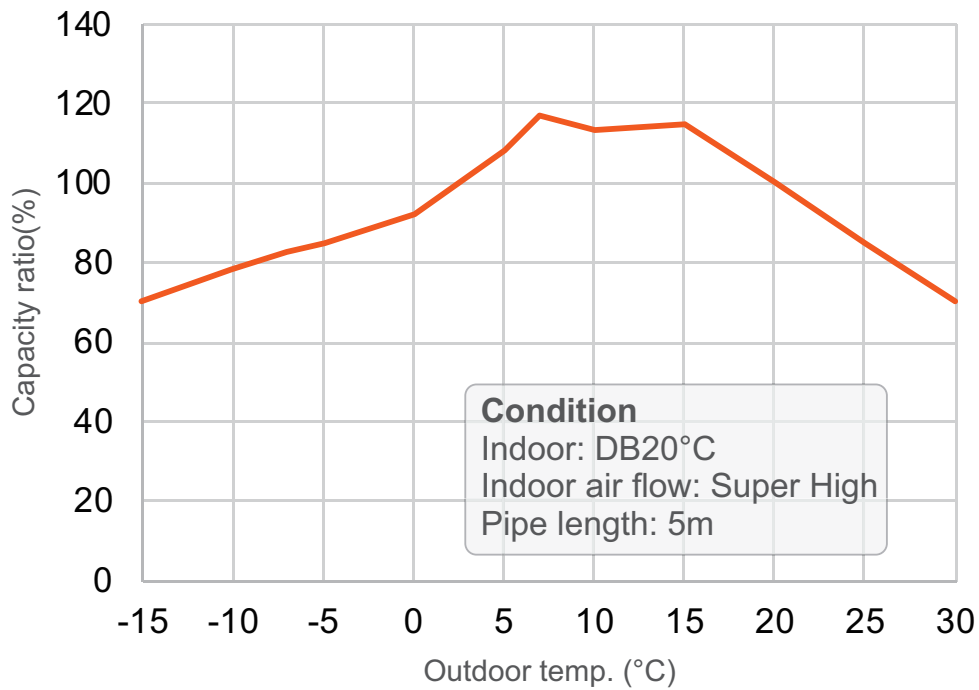
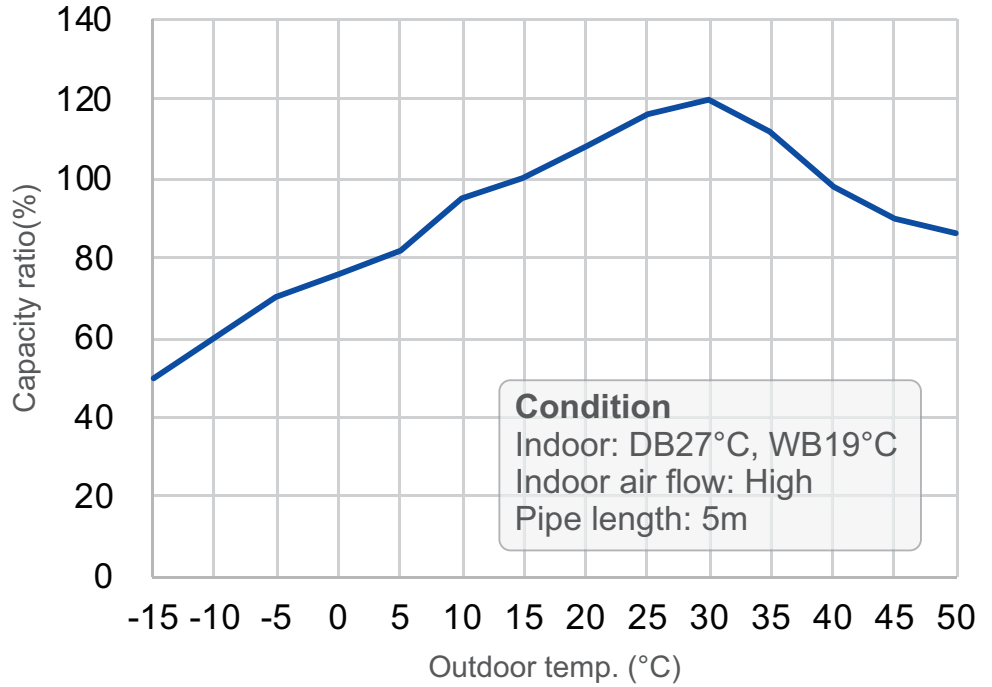

◀ Heating

3.3 Cooling and Heating Data Sheet in Rated Frequency

Cooling

Rated cooling condition (°C) (DB/WB)		Model	Pressure of gas pipe connecting indoor and outdoor unit	Inlet and outlet pipe temperature of heat exchanger		Fan speed of indoor unit	Fan speed of outdoor unit
Indoor	Outdoor			P (MPa)	T1 (°C)		
27/19	35/24	09K	0.8 ~ 1.1	in: 12 out: 15	in: 68 out: 38	Super High	High
27/19	35/24	12K	0.9 ~ 1.1	in: 12 out: 14	in: 75 out: 37	Super High	High
27/19	35/24	18K	0.9 ~ 1.1	in: 12 out: 14	in: 75 out: 37	Super High	High
27/19	35/24	24K	0.9 ~ 1.1	in: 12 out: 14	in: 75 out: 37	Super High	High

Heating

Rated heating condition (°C) (DB/WB)		Model	Pressure of gas pipe connecting indoor and outdoor unit	Inlet and outlet pipe temperature of heat exchanger		Fan speed of indoor unit	Fan speed of outdoor unit
Indoor	Outdoor			P (MPa)	T1 (°C)		
20/-	7/6	09K	2.8 ~ 3.2	in: 63 out: 35	in: 2 out: 5	Super High	High
20/-	7/6	12K	2.2 ~ 2.4	in: 70 out: 35	in: 2 out: 4	Super High	High
20/-	7/6	18K	2.2 ~ 2.4	in: 70 out: 35	in: 1 out: 5	Super High	High
20/-	7/6	24K	2.2 ~ 2.4	in: 70 out: 35	in: 2 out: 4	Super High	High

Instruction

T1: Inlet and outlet pipe temperature of evaporator

T2: Inlet and outlet pipe temperature of condenser

P: Pressure at the side of big valve

Connection pipe length: 5 m.

4. Outline Dimension Diagram

4.1 Indoor Unit

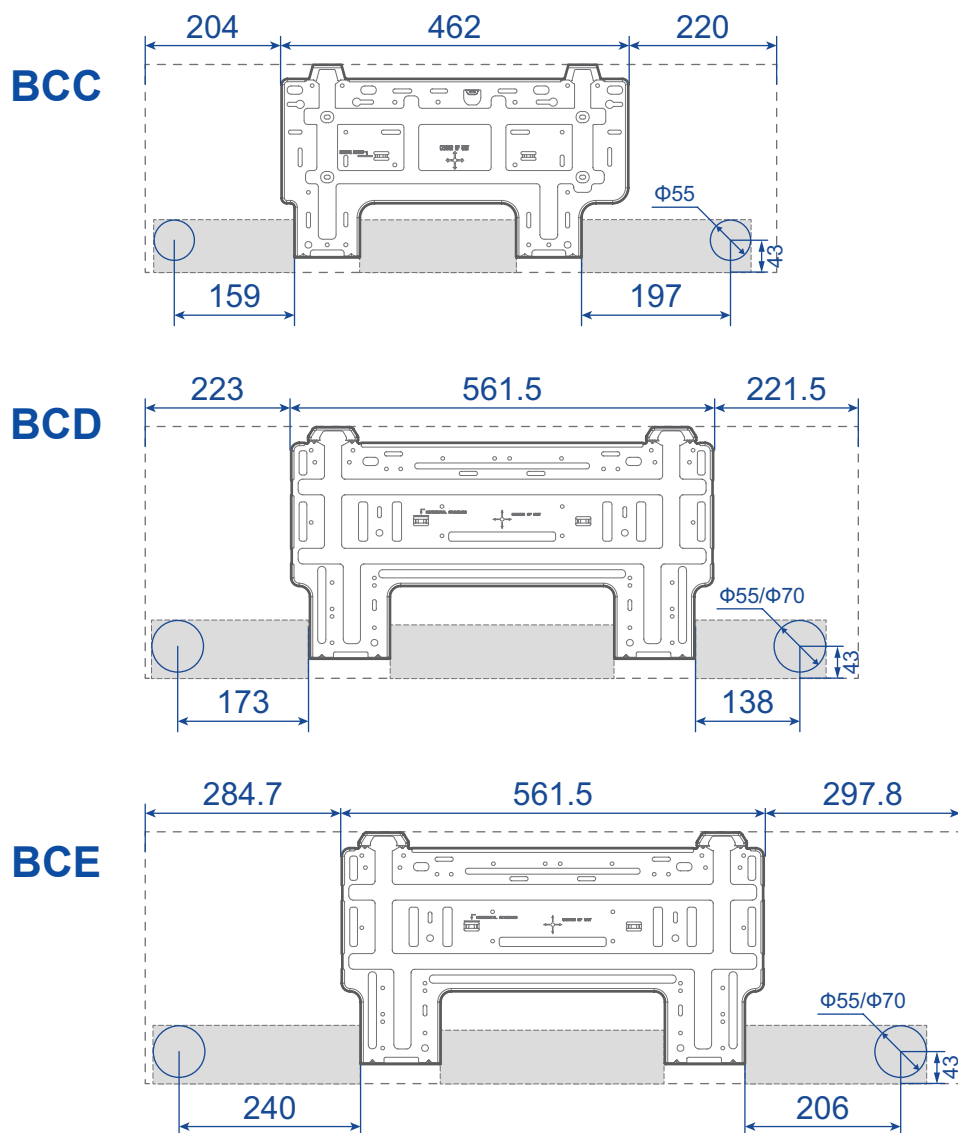
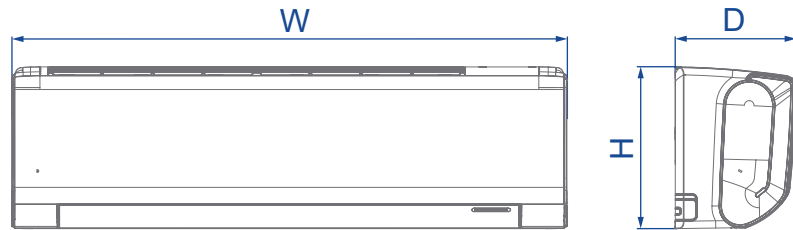

Unit: mm

Indoor Unit Model	W	H	D
BCC	886	276	209
BCD	1006	333	250
BCE	1144	222	250

4.2 Outdoor Unit

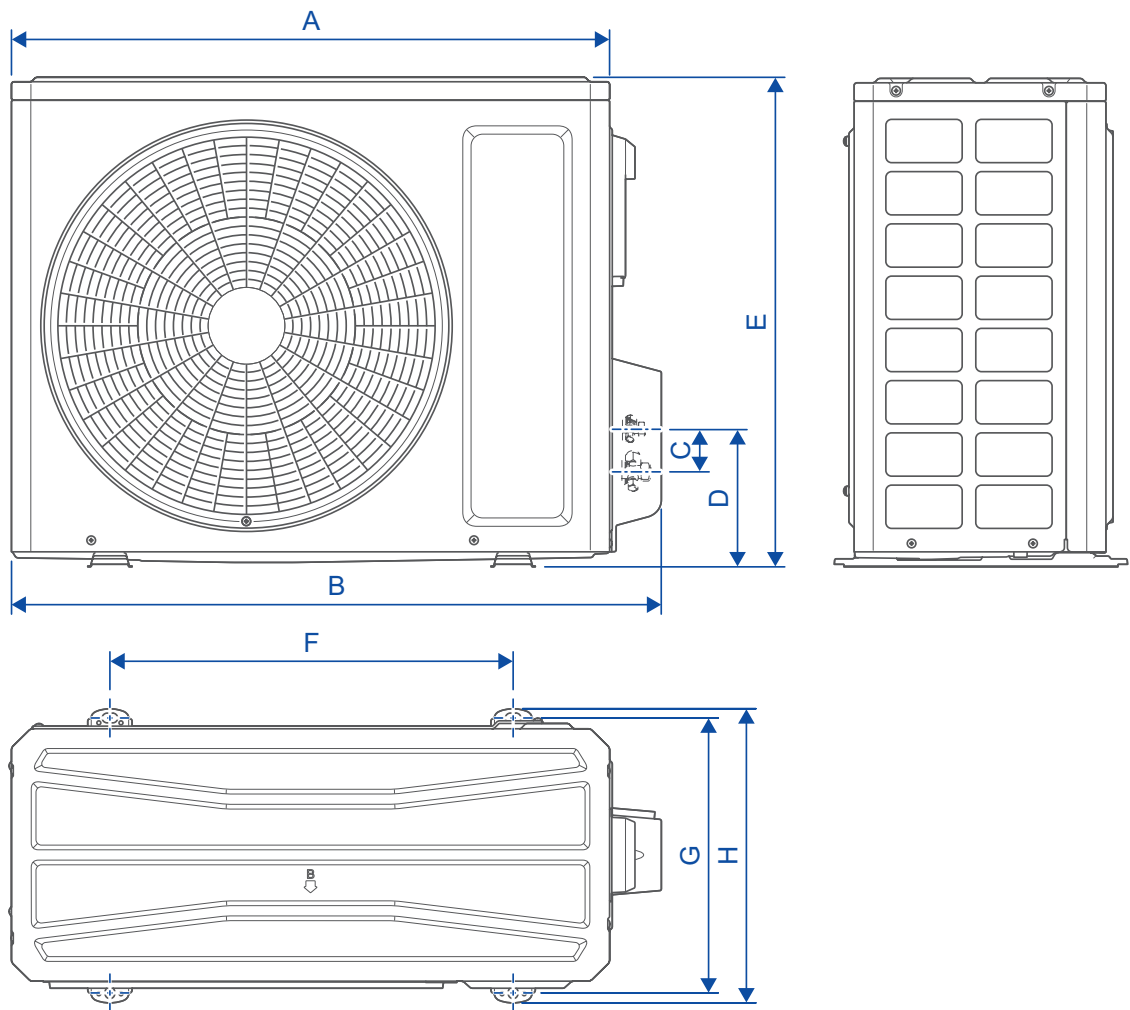

NOTE: The appearance of outdoor unit is for reference only.

Unit: mm

Outdoor Unit Model	A	B	C	D	E	F	G	H
XB	675	732	65	163	555	455	310	330
XD	745	802	65	163	555	513	331	350
XE	805	873	65	164	555	528	349	376
XF	889	958	65	165.6	660	570	371	402