

Model			GWH12AGC-K6DNA1F GWH12AGC-K6DNA4F	GWH12AGC-K6DNA1P
Product Code			CB385009300 CB558002400	CB385009301
Power Supply	Rated Voltage	V~	220-240	220-240
	Rated Frequency	Hz	50	50
	Phases		1	1
Power Supply Mode			Outdoor	Outdoor
Cooling Capacity		W	3510	3510
Heating Capacity		W	3810	3810
Cooling Power Input		W	962	962
Heating Power Input		W	953	953
Cooling Current Input		A	4.3	4.3
Heating Current Input		A	4.6	4.6
Rated Input		W	1550	1550
Rated Cooling Current		A	6.2	6.2
Rated Heating Current		A	6.9	6.9
Air Flow Volume		m ³ /h	680/620/560/490/450/420/390	680/620/560/490/450/420/390
Dehumidifying Volume		L/h	1.4	1.4
EER		W/W	3.649	3.649
COP		W/W	3.998	3.998
SEER			7.1	7.1
SCOP(Average/WarmerColder)			4.1/5.2/3.1	4.1/5.2/3.1
Application Area		m ²	16-24	16-24
Indoor Unit	Model		GWH12AGC-K6DNA1F/I GWH12AGC-K6DNA4F/I	GWH12AGC-K6DNA1P/I
	Product Code		CB385N09300 CB558N02400	CB385N09300
	Fan Type		Cross-flow	Cross-flow
	Fan Diameter Length(DXL)	mm	Φ98×630	Φ98×630
	Cooling Speed	r/min	1300/1150/1100/1000 /950/850/750	1300/1150/1100/1000 /950/850/750
	Heating Speed	r/min	1250/1100/1050/1000/950/850/800	1250/1100/1050/1000/950/850/800
	Fan Motor Power Output	W	20	20
	Fan Motor RLA	A	0.31	0.31
	Fan Motor Capacitor	μF	1.5	1.5
	Evaporator Form		Aluminum Fin-copper Tube	Aluminum Fin-copper Tube
	Evaporator Pipe Diameter	mm	Φ5	Φ5
	Evaporator Row-fin Gap	mm	2-1.4	2-1.4
	Evaporator Coil Length (LXDXW)	mm	634×22.8×304.8	634×22.8×304.8
	Swing Motor Model		MP24BA/MP24AK/MP24HF	MP24BA/MP24AK/MP24HF
	Swing Motor Power Output	W	1.5/1.5/1.5	1.5/1.5/1.5
	Fuse Current	A	3.15	3.15
	Sound Pressure Level	dB (A)	Cooling:41/37/35/32/30/27/24 Heating:40/36/34/32/30/27/24	Cooling:41/37/35/32/30/27/24 Heating:40/36/34/32/30/27/24
	Sound Power Level	dB (A)	Cooling:56/49/47/44/42/39/36 Heating:51/46/44/42/40/37/34	Cooling:56/49/47/44/42/39/36 Heating:51/46/44/42/40/37/34
	Dimension (WXHXD)	mm	825X293X196	825X293X196
	Dimension of Carton Box (LXWXH)	mm	870X349X257	870X349X257
Dimension of Package (LXWXH)	mm	875X365X268	875X365X268	
Net Weight	kg	9.5	9.5	
Gross Weight	kg	11.5	11.5	

Outdoor Unit	Outdoor Unit Model		GWH12AFC-K6DNA2F/O	GWH12AFC-K6DNA2P/O
	Outdoor Unit Product Code		CB363W03600	CB363W03601
	Compressor Manufacturer		ZHUHAI LANDA COMPRESSOR CO., LTD	ZHUHAI LANDA COMPRESSOR CO., LTD
	Compressor Model		FTz-AN108ACBD	FTz-AN108ACBD
	Compressor Oil		FW68DA or equivalent	FW68DA or equivalent
	Compressor Type		Rotary	Rotary
	Compressor LRA.	A	/	/
	Compressor RLA	A	4.4	4.4
	Compressor Power Input	W	/	/
	Compressor Overload Protector		/	/
	Throttling Method		Electron expansion valve	Electron expansion valve
	Set Temperature Range	°C	16~30	16~30
	Cooling Operation Ambient Temperature Range	°C	-15~50	-15~50
	Heating Operation Ambient Temperature Range	°C	-25~30	-15~30
	Condenser Form		Aluminum Fin-copper Tube	Aluminum Fin-copper Tube
	Condenser Pipe Diameter	mm	Φ7.94	Φ7.94
	Condenser Rows-fin Gap	mm	1-1.2	1-1.2
	Condenser Coil Length (LXDXW)	mm	666×19.05×527	666×19.05×527
	Fan Motor Speed	rpm	900	900
	Fan Motor Power Output	W	30	30
	Fan Motor RLA	A	0.4	0.4
	Fan Motor Capacitor	μF	/	/
	Outdoor Unit Air Flow Volume	m ³ /h	1950	1950
	Fan Type		Axial-flow	Axial-flow
	Fan Diameter	mm	400	400
	Defrosting Method		Automatic Defrosting	Automatic Defrosting
	Climate Type		T1	T1
	Isolation		I	I
	Moisture Protection		IPX4	IPX4
	Permissible Excessive Operating Pressure for the Discharge Side	MPa	4.3	4.3
	Permissible Excessive Operating Pressure for the Suction Side	MPa	2.5	2.5
	Sound Pressure Level	dB (A)	52	52
	Sound Power Level	dB (A)	63	63
Dimension(WXHXD)	mm	732X555X330	732X555X330	
Dimension of Carton Box (LXWXH)	mm	791X373X590	791X373X590	
Dimension of Package(LXWXH)	mm	794X376X605	794X376X605	
Net Weight	kg	24.5	24.5	
Gross Weight	kg	27	27	
Refrigerant		R32	R32	
Refrigerant Charge	kg	0.57	0.57	
Connection Pipe	Connection Pipe Length	m	5	5
	Connection Pipe Gas Additional Charge	g/m	16	16
	Outer Diameter Liquid Pipe		1/4"	1/4"
	Outer Diameter Gas Pipe		3/8"	3/8"
	Max Distance Height	m	10	10
	Max Distance Length	m	15	15
	Note: The connection pipe applies metric diameter.			

The above data is subject to change without notice. Please refer to the nameplate of the unit.

2.2 Capacity Variation Ratio According to Temperature

GWH07AGA-K6DNA1A

Cooling

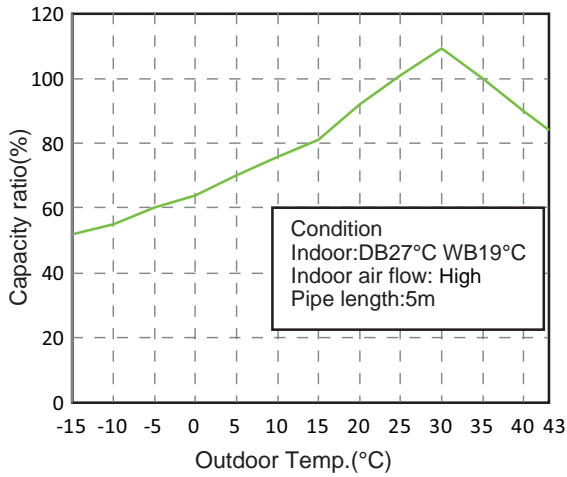

Heating

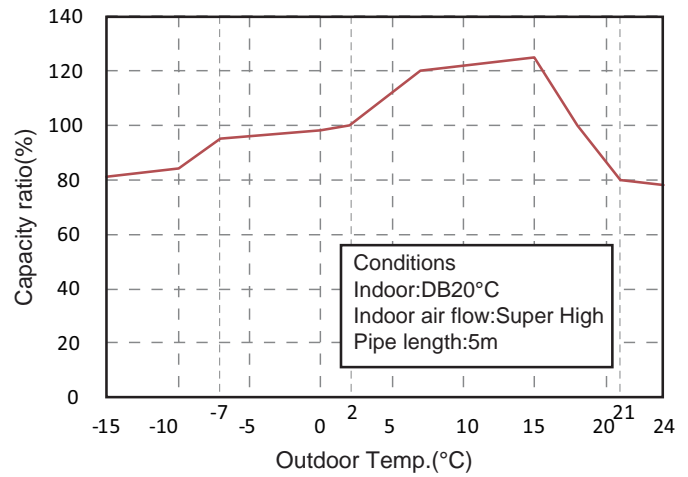

GWH18AGD-K6DNA1D GWH18AGDXB-K6DNA2D GWH18AGD-K6DNA4D GWH24AGD-K6DNA1C GWH24AGD-K6DNA4C

Heating operation ambient temperature range is -15°C~24°C

Cooling

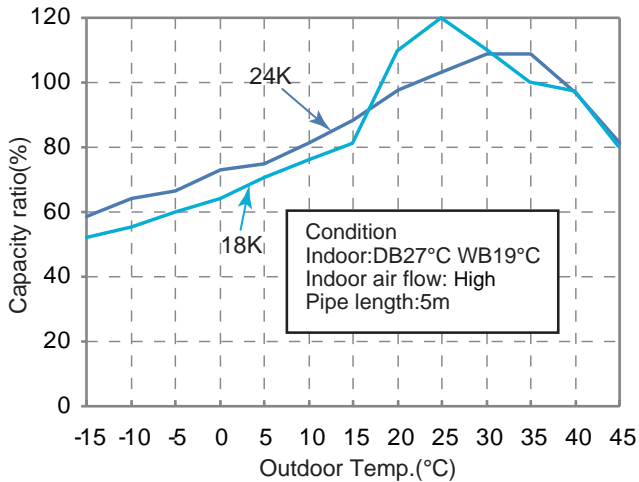

Heating

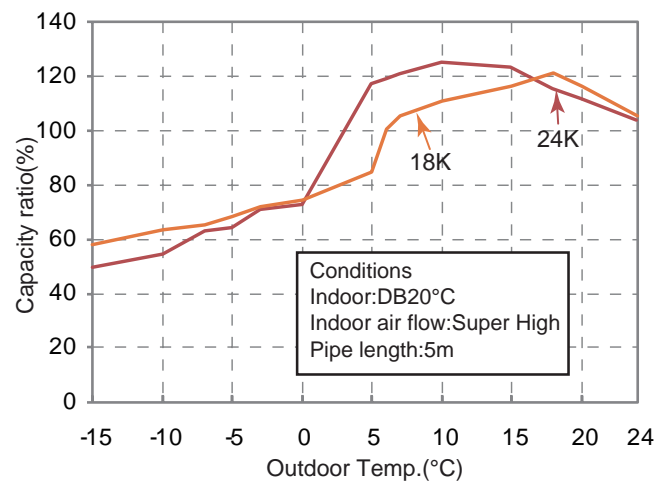

Heating operation ambient temperature range is -15°C~30°C

Cooling

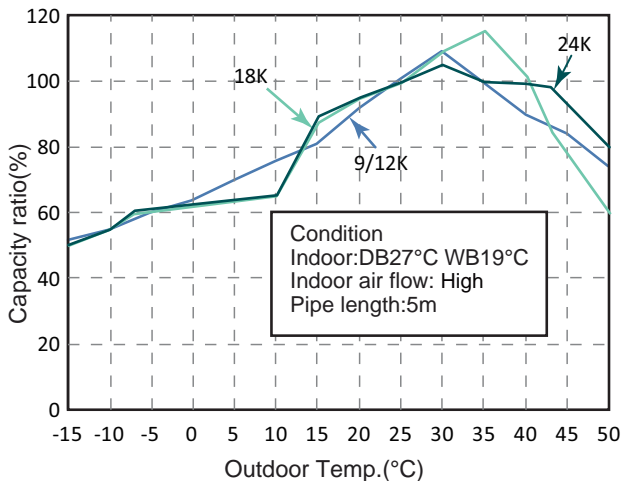

Heating

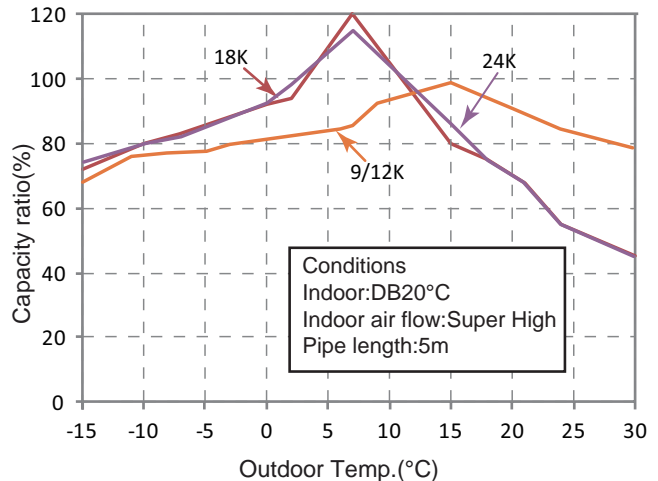

Heating operation ambient temperature range is -25°C~30°C

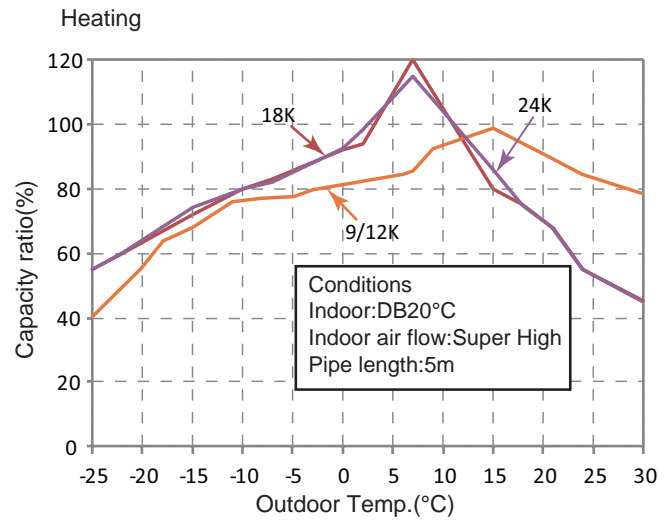
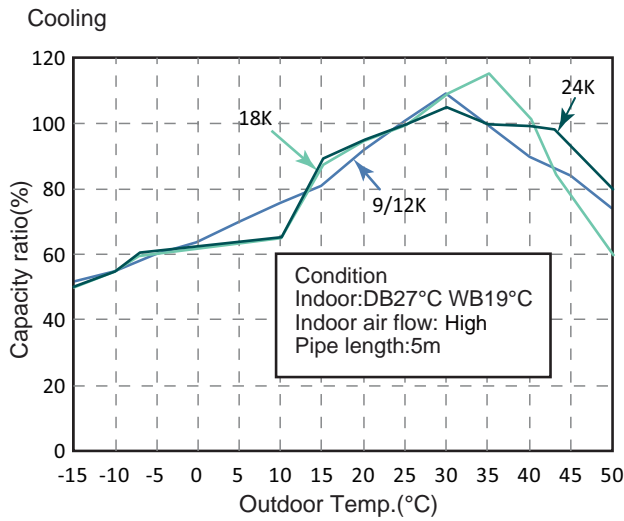

2.3 Cooling and Heating Data Sheet in Rated Frequency

Cooling:

Rated cooling condition(°C) (DB/WB)		Model	Pressure of gas pipe connecting indoor and outdoor unit P (MPa)	Inlet and outlet pipe temperature of heat exchanger		Fan speed of indoor unit	Fan speed of outdoor unit
Indoor	Outdoor			T1 (°C)	T2 (°C)		
27/19	35/24	7/9K	0.8~1.1	12 ~ 15	65 ~ 38	Super High	High
27/19	35/24	12K	0.9~1.1	12 ~ 14	75 ~ 37	Super High	High
27/19	35/24	18K	0.9~1.1	12 ~ 14	75 ~ 37	Super High	High
27/19	35/24	24K	0.9~1.1	12 ~ 14	75 ~ 37	Super High	High

Heating:

Rated heating condition(°C) (DB/WB)		Model	Pressure of gas pipe connecting indoor and outdoor unit P (MPa)	Inlet and outlet pipe temperature of heat exchanger		Fan speed of indoor unit	Fan speed of outdoor unit
Indoor	Outdoor			T1 (°C)	T2 (°C)		
20/-	7/6	7/9K	2.8~3.2	63 ~ 35	2 ~ 5	Super High	High
20/-	7/6	12K	2.2~2.4	70 ~ 35	2 ~ 4	Super High	High
20/-	7/6	18K	2.2~2.4	70 ~ 40	1 ~ 5	Super High	High
20/-	7/6	24K	2.2~2.4	70 ~ 35	2 ~ 4	Super High	High

Instruction:

T1: Inlet and outlet pipe temperature of evaporator

T2: Inlet and outlet pipe temperature of condenser

P: Pressure at the side of big valve

Connection pipe length: 5 m.

3. Outline Dimension Diagram

3.1 Indoor Unit

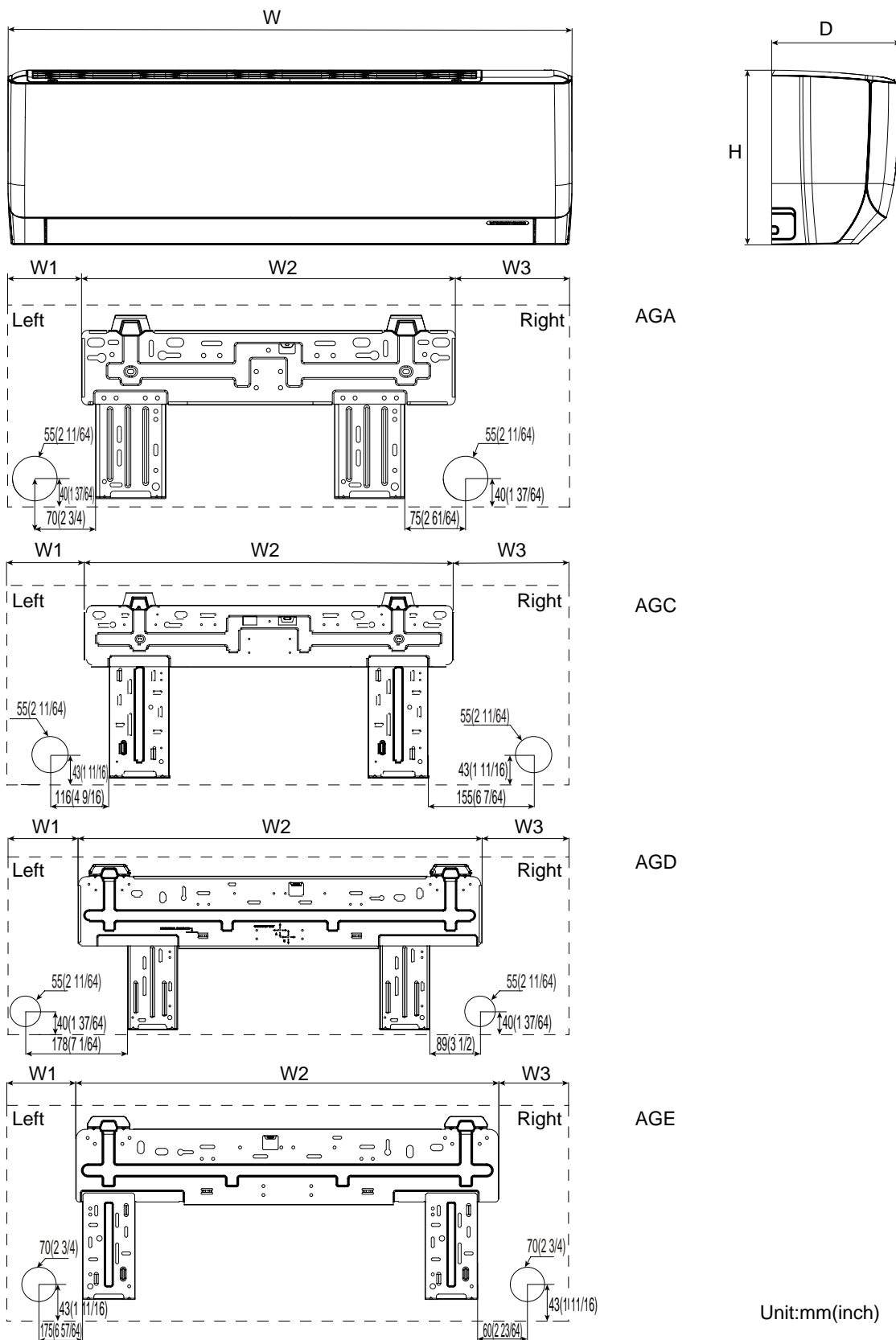

Model	W	H	D	W1	W2	W3
AGA	704	260	185	93	462	149
AGC	825	293	196	113	542	170
AGD	982	311	221	122.5	707.5	152
AGE	1075	333	246	184	707.5	183.5

Unit:mm

3.2 Outdoor Unit

GWH07AGA-K6DNA1A/O

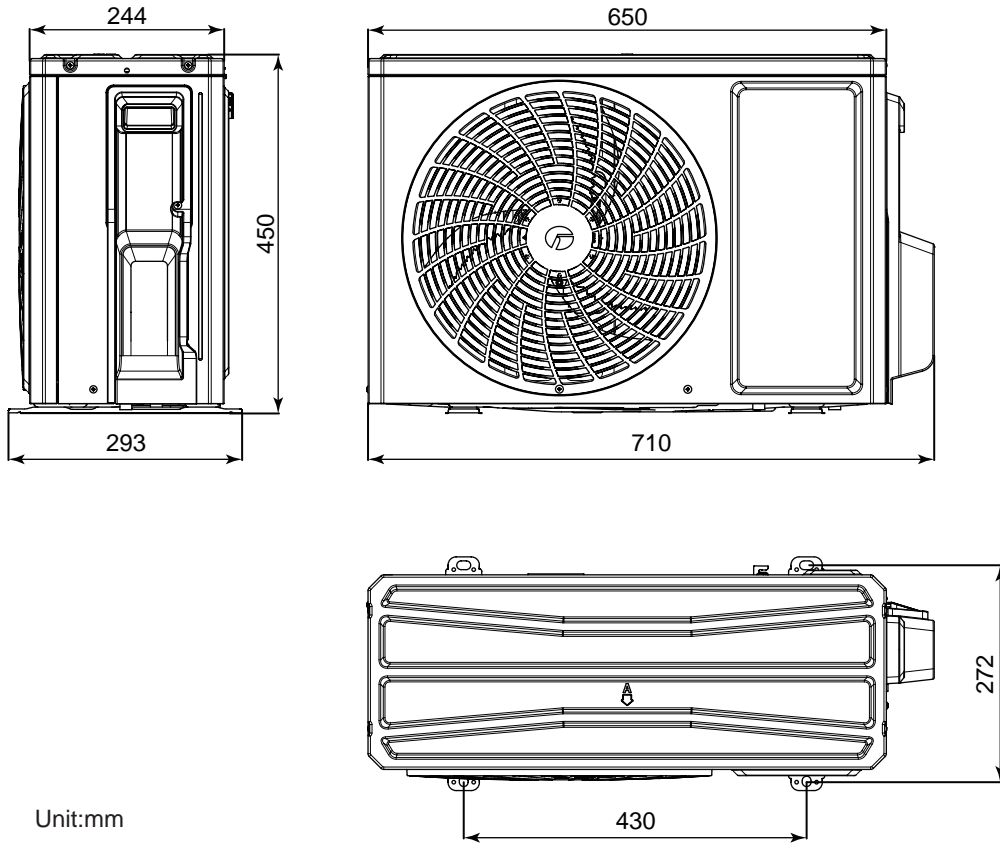

GWH09AFC-K6DNA2P/O GWH12AFC-K6DNA2P/O GWH18AGD-K6DNA1P/O GWH12AGCXB-K6DNA1E/O

